

**CHEVROLET / GMC
UNDER-FRAME MOUNT
INSTALLATION INSTRUCTIONS
FOR SINGLE-STAGE AND
TWO-STAGE TAILGATE SPREADERS**

**The under-frame mount is recommended for use on the following vehicles with an 8 foot box:
1988-1996 Chevrolet / GMC - 1500 / 2500 / 2500 HD / 3500.**

This mount is NOT applicable to trucks equipped with a short (6-1/2 foot) box.

Read and understand Installation Instructions before installing the under-frame mount.

TABLE OF CONTENTS

TABLE OF CONTENTS

SAFETY	1
Safety Definitions	1
Safety Procedures	1
Battery Safety	1
WEIGHT RESTRICTIONS	2
UNDER-FRAME MOUNT INSTALLATION	3
Rear Brackets Installation	3
Subframe Assembly	4
Subframe Assembly Installation	4
Secondary Frame Assembly	5
Mounting the Secondary Frame	5
Hopper Installation	5
ABBREVIATION KEY	7
PARTS LIST	8
Under-Frame Mount Assembly	8
Chevrolet / GMC Mounts	10

Douglas Dynamics reserves the right under its product improvement procedures to change construction or design details and furnish equipment when so altered without reference to illustrations or specifications used herein.

SAFETY

Safety Definitions

Read this manual and all spreader labels before installing or operating the spreader.



WARNING: The symbol at left identifies a **SAFETY WARNING** that indicates a potentially hazardous situation that, if not avoided, could result in death or serious personal injury.

CAUTION: Indicates a situation that, if not avoided, could result in damage to product or property.

NOTE: Identifies tips, helpful hints, and maintenance information the reader should know.

Safety Procedures

Observe the following safety procedures before and during the use of the spreader. By following these rules and applying common sense, possible personal injury and potential damage to the machine may be avoided.



WARNING:

- Before starting the spreader, verify all personnel and equipment are clear of the spreader spray area.

CAUTION:

- Do not operate a spreader in need of maintenance.
- Before operating the spreader, reassemble any parts or hardware removed for cleaning or adjusting.
- Before operating the spreader, remove materials such as cleaning rags, brushes, and hand tools from the spreader.

NOTE: If the spreader obstructs the view of the license plate, check for any local regulations that may apply.

NOTE: If rear directional/brake lights are obstructed when mounting the spreader, the lights must be relocated, or auxiliary directional/brake lights must be installed to side of spreader brackets.

Battery Safety



WARNING: Follow these warnings to avoid personal injury and damage to product or property.

- Avoid exposing battery to a spark or flame.
- Always charge battery in a well ventilated area.
- Avoid contact with battery acid.
- Always disconnect battery before removing or replacing any electrical components.
- Never lay anything on a battery. This could result in electrical shock or burns and could cause explosions.

WEIGHT RESTRICTIONS



WARNING: The use of under-frame or in-bed mounts on half-ton trucks is restricted to spreading only salt or calcium chloride (max. 70 lb. per cu. ft.). Failure to comply could result in exceeding the payload capacity. See Figures 1 & 2.



WARNING: Check the vehicle's load rating certification sticker for maximum vehicle capacity and **DO NOT** load beyond the vehicle GVWR or GAWR. Overloading could result in an accident or damage to the vehicle.

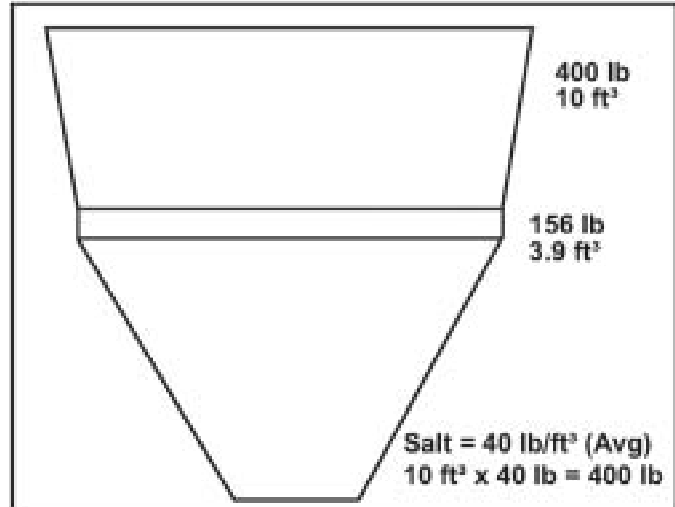

Figure 2

Very Coarse = 35 lb/ft³
Coarse = 45 lb/ft³
Fine = 50 lb/ft³

The following table gives information regarding the Class IV receiver hitch.

HITCH TYPE	MAX. GROSS TRLR WT (LB.)	MAX. TONGUE WT (LB.)
WEIGHT DISTRIBUTING	10,000	1000
WEIGHT CARRYING BALL MOUNT	10,000	1000

When tightening fasteners, refer to Table 1, Torque Chart, for the recommended fastener values.

Table 1: Torque Chart

Recommended Fastener Torque Chart (Ft.-Lb.)			
Size	SAE Grade 2	SAE Grade 5	SAE Grade 8
1/4-20	6	9	13
5/16-18	11	18	28
3/8-16	19	31	48
3/8-24	24	48	68
7/16-14	30	50	75
1/2-13	45	75	115
9/16-12	68	110	165
5/8-11	95	150	225
Metric Grade 8.8 (Ft.-Lb.)			
Size	Torque	Size	Torque
M 6	7	M 12	60
M 8	17	M 14	95

These torque values apply to mount assembly fasteners except those noted in the instruction.

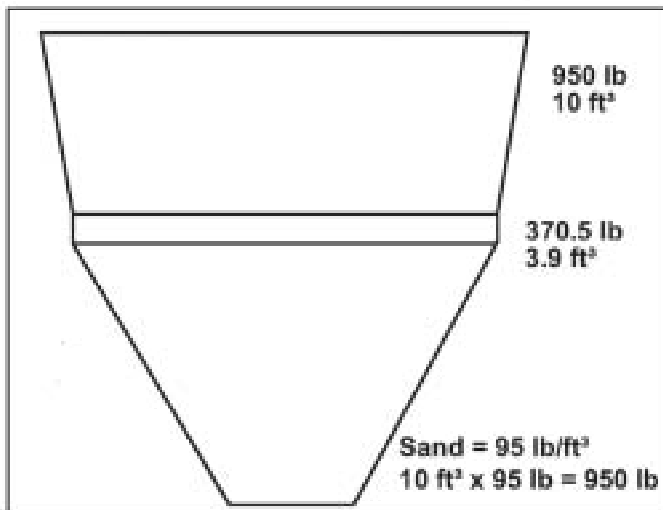

Figure 1

UNDER-FRAME MOUNT INSTALLATION

NOTE: Remove any existing trailer hitch and other after-market equipment which may interfere with the installation of this product according to these instructions.



WARNING: Before working with the spreader, secure all loose fitting clothing and unrestrained hair.

NOTE: Install all fasteners finger tight until assembly is complete. Then tighten according to the Torque Chart on page 2.

Rear Brackets Installation

1. Remove outboard bumper brackets by removing two bolts from vehicle frame and two bolts securing bracket to bumper. See Figure 3.

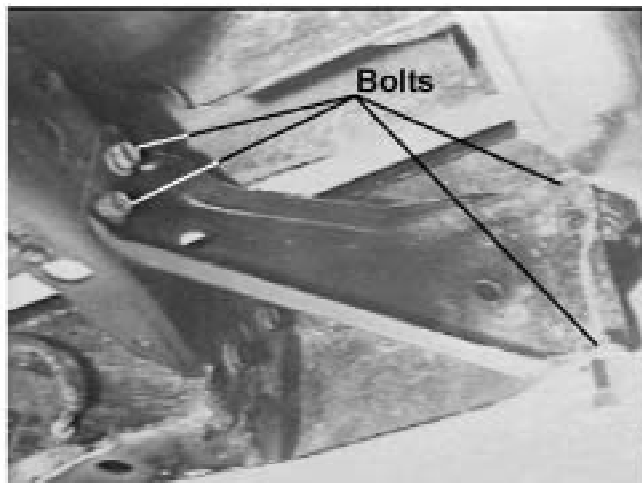

Figure 3
Driver's Side Shown

2. Position rear subframe mounting brackets to vehicle frame and align holes. Position outboard bumper brackets over subframe mounting brackets. Install one 1/2" x 1-3/4" grade 8 bolt and 1/2" flat washer through the bottom hole in the bumper bracket, subframe mounting bracket, and vehicle frame. Retain with 1/2" flat washer and 1/2" locknut. See Figure 4.

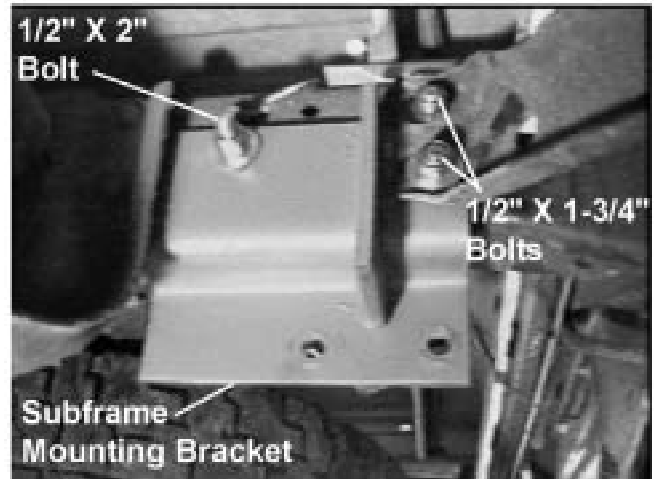

Figure 4
Driver's Side Shown

3. Install one 1/2" x 1-3/4" grade 8 bolt and 1/2" flat washer through upper bumper bracket hole, three 1/2" flat washers (between bumper bracket and vehicle frame), and vehicle frame. Retain with a 1/2" flat washer and a 1/2" locknut. See Figure 4.
4. Install one 1/2" x 2" grade 5 bolt and 1/2" flat washer through front hole in subframe mounting bracket and vehicle frame. Retain with 1/2" flat washer and 1/2" locknut. See Figure 4.
5. Install original bumper bracket bolts in bumper.

UNDER-FRAME MOUNT INSTALLATION

Subframe Assembly

1. Insert receiver hitch into subframe mounts to furthest (narrow) position and align holes.
2. Install two 5/8" x 4" grade 8 bolts per side (four total) and washers (one on each side of the crosstube). See Figure 5.



Figure 5

3. Position front brackets outside of subframe and retain with one 1/2" x 1-3/4" grade 5 bolt, 1/2" flat washer and 1/2" locknut. See Figure 6.

NOTE: Driver-side bracket has a notch on top facing front. Curb-side bracket has a bevel on top facing front.

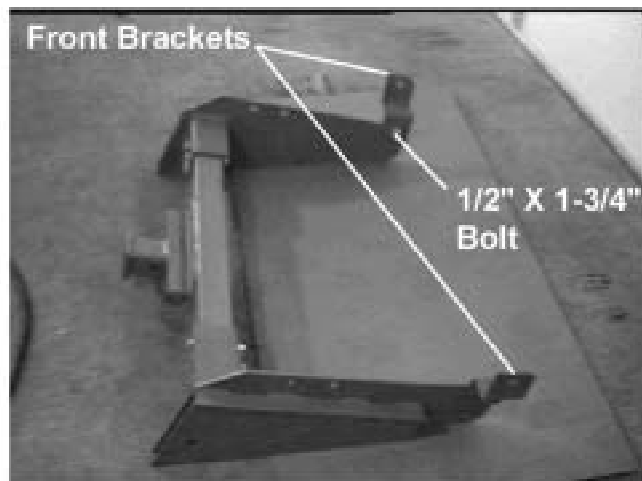

Figure 6

Subframe Assembly Installation

1. Position assembled subframe under truck between two rear subframe brackets.
2. Install two 1/2" x 1-3/4" grade 5 bolt, 1/2" flat washer and 1/2" locknut (per side) to hold subframe to rear brackets.
3. Swing front of subframe assembly up until front brackets are seated against bottom frame flange.

CAUTION: Before drilling any holes, check both sides of the material for any wires, fuel lines, fuel tanks, etc. that may be damaged by drilling.

4. Using bracket as a template, center punch and drill a 17/32" hole in vertical web of frame, one on each side. See Figure 7.

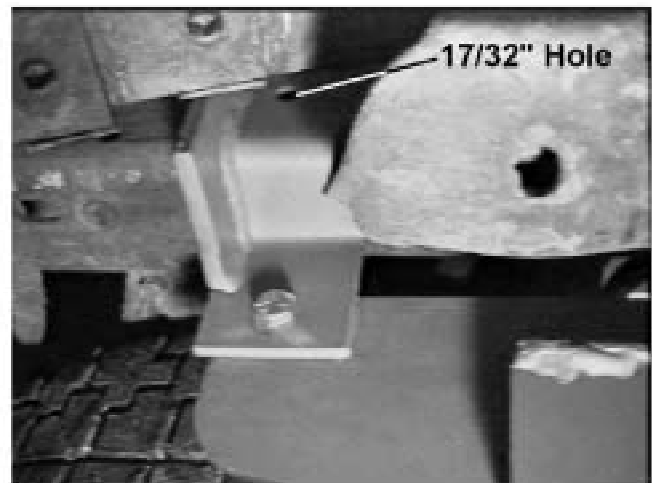

Figure 7

Driver's Side Shown

5. Install one 1/2" x 2" grade 5 bolt and 1/2" flat washer (per side) with the head of the bolt inside the web of the frame. Retain with 1/2" flat washer and 1/2" locknut.
6. Tighten all fasteners according to the Torque Chart on page 2.

UNDER-FRAME MOUNT INSTALLATION

Secondary Frame Assembly

1. Position center secondary frame sections between curb- and driver-side secondary frame sections. See Under-Frame Mount Assembly drawing on page 8.

NOTE: Secondary frame must be assembled with mount bars to inside of vertical tubes. Top of center section should be approximately six inches above top of vertical tubes. The notch in the top cross-member must face rearward.

NOTE: Center secondary frame may be assembled three or six inches lower for use with higher trucks.

2. Align holes and install six 3/8" x 2-1/2" grade 8 bolts through vertical tubes and center section sideplate. Retain with flat washer and locknuts, three on each side.
3. Tighten all fasteners according to the Torque Chart on page 2.

Mounting the Secondary Frame

1. Position secondary frame behind truck and insert mount bars of secondary frame into subframe pockets. See Figure 8.



Figure 8

2. Slide secondary frame into subframe until 3/4" holes align.
3. Install two 3/4" pins through subframe and secondary frame.
4. Retain 3/4" pins by installing 3/16" linchpin into hole in 3/4" pins. See Figure 9.



Figure 9

Hopper Installation

1. Lift hopper assembly and tip slightly forward. See Figure 10.



Figure 10

UNDER-FRAME MOUNT ASSEMBLY

2. Position tabs on the hopper assembly over the top of the installed secondary frame assembly and lower the hopper assembly. See Figure 11.

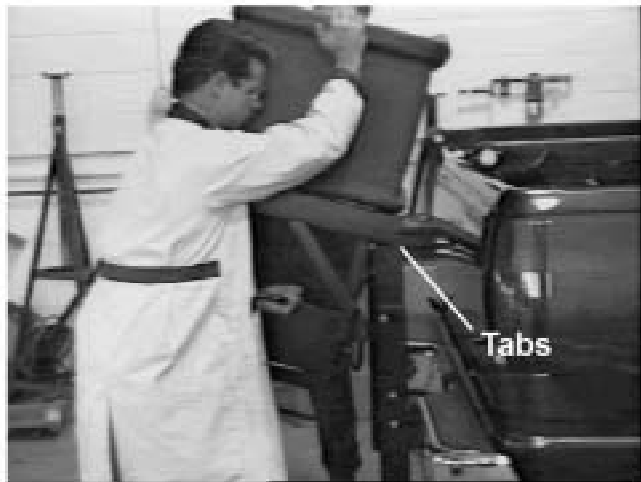

Figure 11

3. Allow hopper assembly to rotate until the bottom contacts secondary frame assembly.
4. Insert hold-down pins on each side and secure with hairpin cotters. See Figure 12.

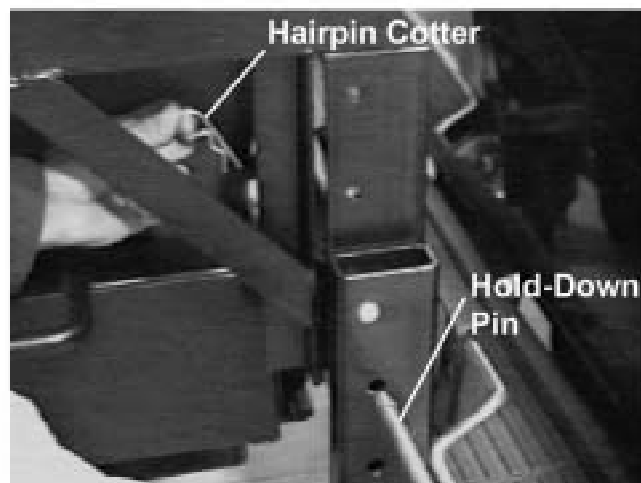

Figure 12

5. Connect spreader-side wiring harness to vehicle-side wiring harness. See Figure 13.

NOTE: Grease the electrical connections using dielectric grease.

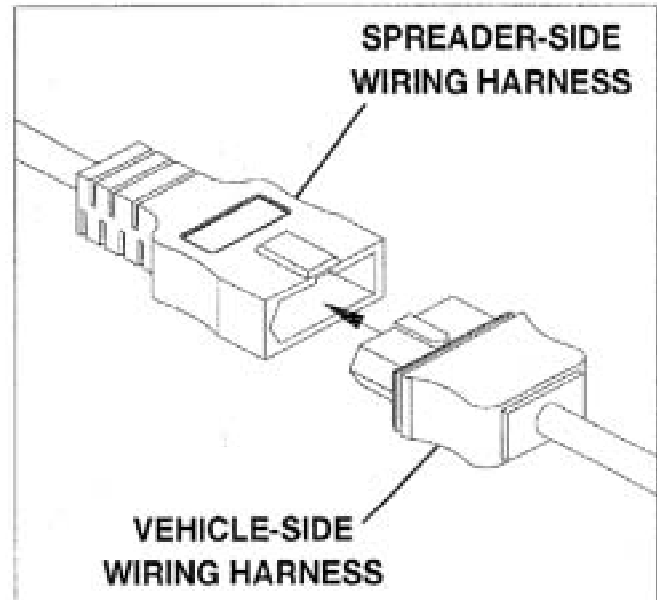

Figure 13

CAUTION: Both pins must be in place and secured with hairpin cotter pins. The hopper assembly may become unstable if the pins are not properly secure while the vehicle is in motion.

ABBREVIATION KEY

ASSY	Assembly	NYIS	Nylon Insert
CS	Cap Screw	PT	Prevailing Torque
CTR	Center	SAE	Society of Automotive Engineers
CU	Curb-Side	STD	Standard
DR	Driver-Side	TY	Type
G	Grade	ZP	Zinc Plate
HX	Hex	ZYC	Zinc Yellow Chromate
LK	Lock		

PARTS LIST

Under-Frame Mount Assembly

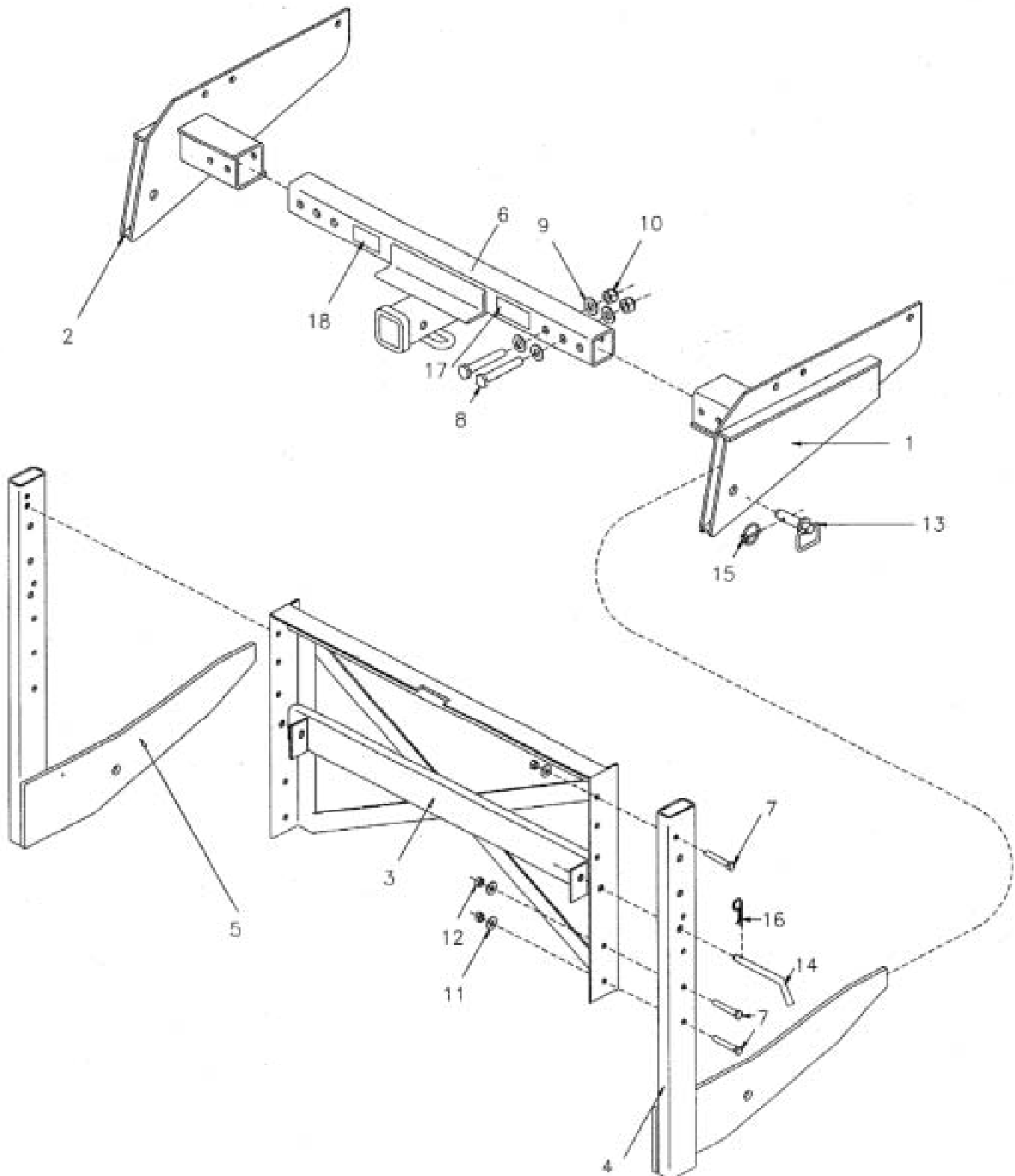

PARTS LIST

Under-Frame Mount Assembly

ITEM	QTY.	DESCRIPTION
1	1	MOUNT SUBFRAME - CU
2	1	MOUNT SUBFRAME - DR
3	1	SECONDARY FRAME - CTR
4	1	SECONDARY FRAME
5	1	SECONDARY FRAME
6	1	RECEIVER HITCH W/ LABELS (includes items 17 and 18)
7	6	3/8-16X2-1/2 HX CS G8 ZYC
8	4	5/8-11X4 HX CS G8 ZYC
9	8	5/8 PLAIN WASHER TY A SAE ZP
10	4	5/8-11 PT HX LK NUT NYIS ZYC
11	6	3/8 PLAIN WASHER TY A STD ZP
12	6	3/8-16 PT HX LK NUT NYIS ZYC
13	2	3/4X2-3/4 HITCH PIN ZYC
14	2	PIN 1/2"X5.5"
15	2	LINCHPIN 3/16"
16	2	HAIRPIN COTTER 1/8"
17	1	LABEL - INFORMATION (WARNING)
18	1	LABEL - INFORMATION (RATING)

Parts 7-15 are found in the following assembly:

- 1 BOLT BAG ASSY

NOTE: See *Owner's Manual* for repair part numbers.

PARTS LIST

Chevrolet / GMC Mounts

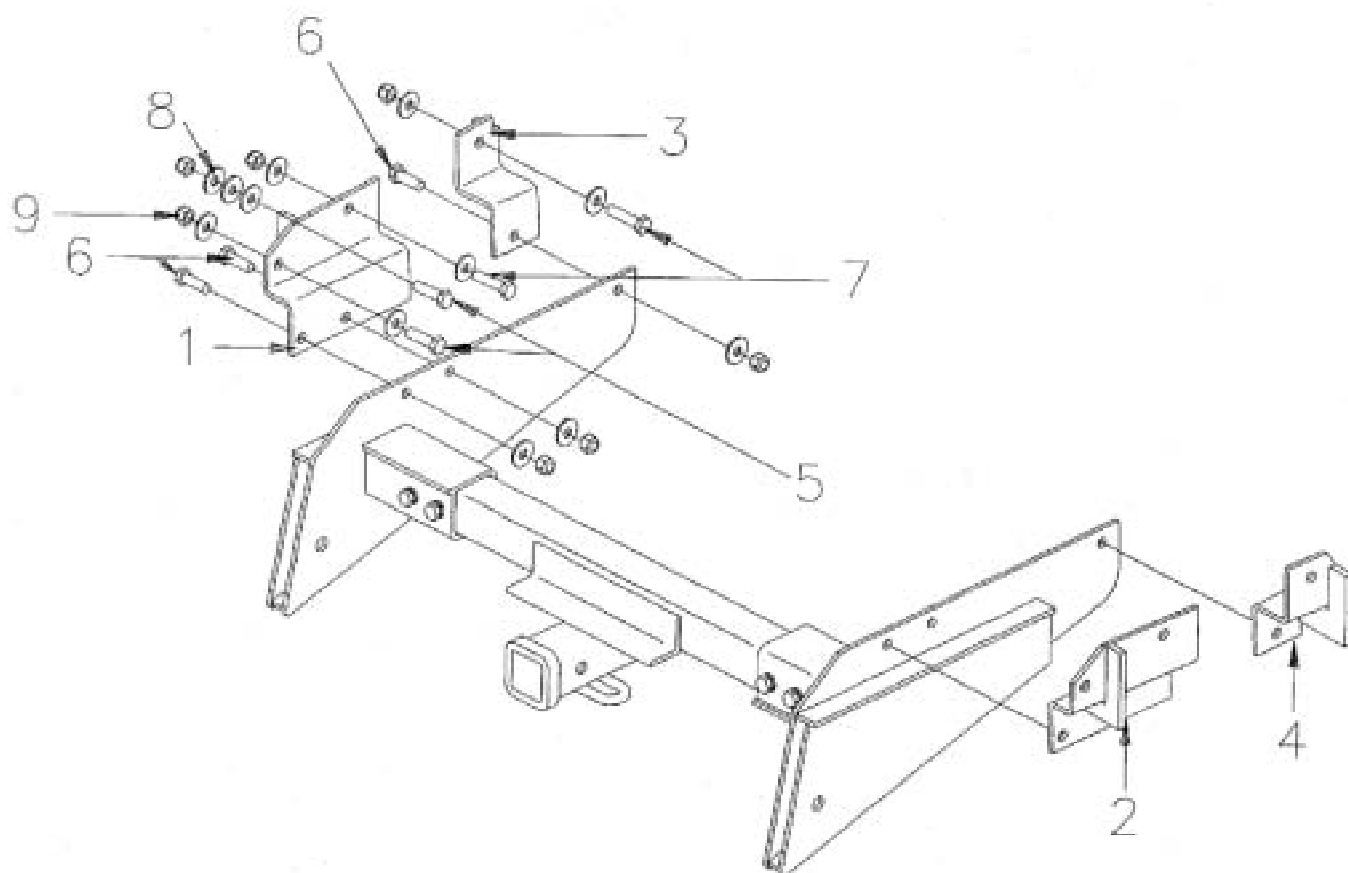

ITEM	QTY.	DESCRIPTION
1	1	MOUNT BRACKET-GM-REAR-DR
2	1	MOUNT BRACKET-GM-REAR-CU
3	1	MOUNT BRACKET-GM-FRONT-DR
4	1	MOUNT BRACKET-GM-FRONT-CU
5	4	1/2-13X1-3/4 HX CS G8 ZYC
6	6	1/2-13 X 1-3/4 HX CS G5 ZP
7	4	1/2-13 X 2 HX CS G5 ZP
8	24	1/2 PLAIN WASHER TY A STD ZYC
9	14	1/2-13 PT HX LK NUT NYIS ZYC

NOTE: See *Owner's Manual* for repair part numbers.